

μA741

FREQUENCY-COMPENSATED OPERATIONAL AMPLIFIER

FAIRCHILD LINEAR INTEGRATED CIRCUITS

GENERAL DESCRIPTION — The μA741 is a high performance monolithic operational amplifier constructed on a single silicon chip, using the Fairchild Planar* epitaxial process. It is intended for a wide range of analog applications. High common mode voltage range and absence of "latch-up" tendencies make the μA741 ideal for use as a voltage follower. The high gain and wide range of operating voltage provides superior performance in integrator, summing amplifier, and general feedback applications.

- NO FREQUENCY COMPENSATION REQUIRED
- SHORT-CIRCUIT PROTECTION
- OFFSET VOLTAGE NULL CAPABILITY
- LARGE COMMON-MODE AND DIFFERENTIAL VOLTAGE RANGES
- LOW POWER CONSUMPTION
- NO LATCH UP

ABSOLUTE MAXIMUM RATINGS

Supply Voltage	
Military (312 Grade)	±22 V
Commercial (393 Grade)	±18 V
Internal Power Dissipation (Note 1)	
Metal Can	500 mW
Ceramic DIP	670 mW
Silicone DIP	340 mW
Mini DIP	310 mW
Flatpak	570 mW
Differential Input Voltage	±30 V
Input Voltage (Note 2)	±15 V
Storage Temperature Range	
Metal Can, Ceramic DIP, and Flatpak	-65°C to +150°C
Mini DIP and Silicon DIP	-55°C to +125°C
Operating Temperature Range	
Military (312 Grade)	-55°C to +125°C
Commercial (393 Grade)	0°C to + 70°C
Lead Temperature (Soldering)	
Metal Can, Ceramic DIP and Flatpak (60 seconds)	300°C
Mini DIP and Silicone DIP (10 seconds)	260°C
Output Short Circuit Duration (Note 3)	Indefinite

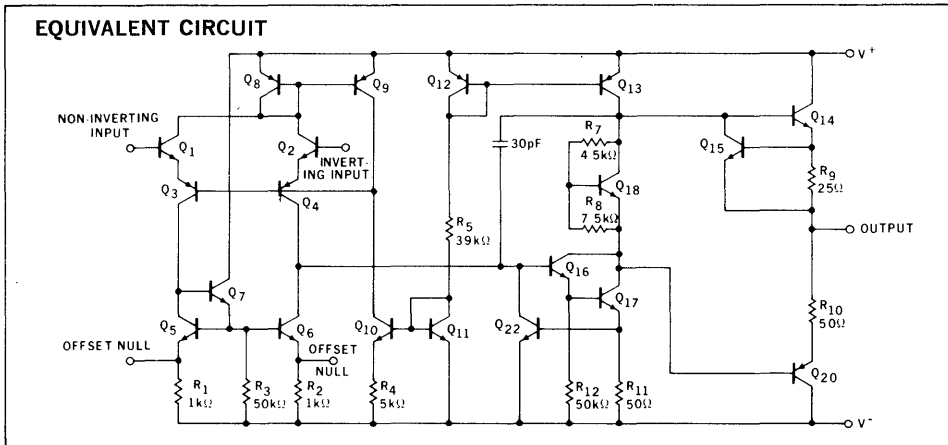

Notes on following pages.

**CONNECTION DIAGRAMS
(TOP VIEW)**

8 LEAD METAL CAN

NOTE: PIN 4 CONNECTED TO CASE

ORDER PART NOS.
U5B7741312
U5B7741393

14 LEAD DIP

FOR CERAMIC DIP ORDER PART NOS.
U6A7741312
U6A7741393

FOR SILICONE DIP ORDER PART NO.:
U9A7741393

FLATPACK

ORDER PART NO.
U3F7741312

MINIDIP

ORDER PART NO.
U9T7741393

*Planar is a patented Fairchild process.

312 GRADE

ELECTRICAL CHARACTERISTICS ($V_S = \pm 15\text{ V}$, $T_A = 25^\circ\text{C}$ unless otherwise specified)

PARAMETERS (see definitions)	CONDITIONS	MIN.	TYP.	MAX.	UNITS
Input Offset Voltage	$R_S \leq 10\text{ k}\Omega$		1.0	5.0	mV
Input Offset Current			20	200	nA
Input Bias Current			80	500	nA
Input Resistance		0.3	2.0		M Ω
Input Capacitance			1.4		pF
Offset Voltage Adjustment Range			± 15		mV
Large-Signal Voltage Gain	$R_L \geq 2\text{ k}\Omega$, $V_{out} = \pm 10\text{ V}$	50,000	200,000		
Output Resistance			75		Ω
Output Short-Circuit Current			25		mA
Supply Current			1.7	2.8	mA
Power Consumption			50	85	mW
Transient Response (unity gain)	$V_{in} = 20\text{ mV}$, $R_L = 2\text{ k}\Omega$, $C_L \leq 100\text{ pF}$				
Risetime			0.3		μs
Overshoot			5.0		%
Slew Rate	$R_L \geq 2\text{ k}\Omega$		0.5		V/ μs
The following specifications apply for $-55^\circ\text{C} \leq T_A \leq +125^\circ\text{C}$:					
Input Offset Voltage	$R_S \leq 10\text{ k}\Omega$		1.0	6.0	mV
Input Offset Current	$T_A = +125^\circ\text{C}$		7.0	200	nA
	$T_A = -55^\circ\text{C}$		85	500	nA
Input Bias Current	$T_A = +125^\circ\text{C}$		0.03	0.5	μA
	$T_A = -55^\circ\text{C}$		0.3	1.5	μA
Input Voltage Range		± 12	± 13		V
Common Mode Rejection Ratio	$R_C \leq 10\text{ k}\Omega$	70	90		dB
Supply Voltage Rejection Ratio	$R_S \leq 10\text{ k}\Omega$		30	150	$\mu\text{V/V}$
Large-Signal Voltage Gain	$R_L \geq 2\text{ k}\Omega$, $V_{out} = \pm 10\text{ V}$	25,000			
Output Voltage Swing	$R_L \geq 10\text{ k}\Omega$	± 12	± 14		V
	$R_L \geq 2\text{ k}\Omega$	± 10	± 13		V
Supply Current	$T_A = +125^\circ\text{C}$		1.5	2.5	mA
	$T_A = -55^\circ\text{C}$		2.0	3.3	mA
Power Consumption	$T_A = +125^\circ\text{C}$		45	75	mW
	$T_A = -55^\circ\text{C}$		60	100	mW

TYPICAL PERFORMANCE CURVES
312 GRADE

OPEN LOOP VOLTAGE GAIN AS A FUNCTION OF SUPPLY VOLTAGE

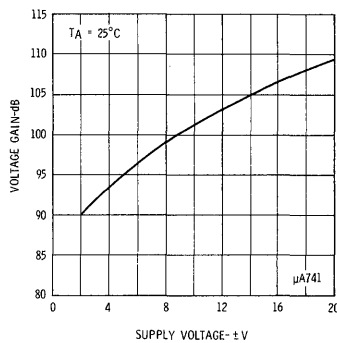

OUTPUT VOLTAGE SWING AS A FUNCTION OF SUPPLY VOLTAGE

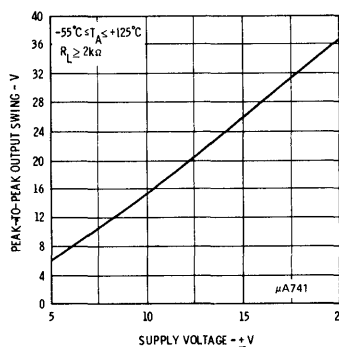

INPUT COMMON MODE VOLTAGE RANGE AS A FUNCTION OF SUPPLY VOLTAGE

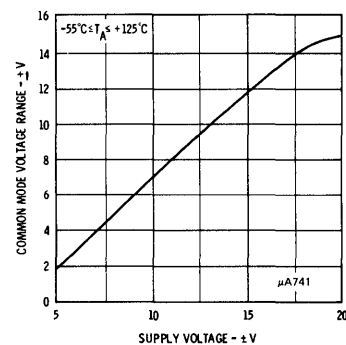

393 GRADE

ELECTRICAL CHARACTERISTICS ($V_S = \pm 15\text{ V}$, $T_A = 25^\circ\text{C}$ unless otherwise specified)

PARAMETERS (see definitions)	CONDITIONS	MIN.	TYP.	MAX.	UNITS
Input Offset Voltage	$R_S \leq 10\text{ k}\Omega$		2.0	6.0	mV
Input Offset Current			20	200	nA
Input Bias Current			80	500	nA
Input Resistance		0.3	2.0		M Ω
Input Capacitance			1.4		pF
Offset Voltage Adjustment Range			± 15		mV
Input Voltage Range		± 12	± 13		V
Common Mode Rejection Ratio	$R_S \leq 10\text{ k}\Omega$	70	90		dB
Supply Voltage Rejection Ratio	$R_S \leq 10\text{ k}\Omega$		30	150	$\mu\text{V/V}$
Large-Signal Voltage Gain	$R_L \geq 2\text{ k}\Omega$, $V_{out} = \pm 10\text{ V}$	20,000	200,000		
Output Voltage Swing	$R_L \geq 10\text{ k}\Omega$	± 12	± 14		V
	$R_L \geq 2\text{ k}\Omega$	± 10	± 13		V
Output Resistance			75		Ω
Output Short-Circuit Current			25		mA
Supply Current			1.7	2.8	mA
Power Consumption			50	85	mW
Transient Response (unity gain)	$V_{in} = 20\text{ mV}$, $R_L = 2\text{ k}\Omega$, $C_L \leq 100\text{ pF}$				
Risetime			0.3		μs
Overshoot			5.0		%
Slew Rate	$R_L \geq 2\text{ k}\Omega$		0.5		V/ μs

The following specifications apply for $0^\circ\text{C} \leq T_A \leq +70^\circ\text{C}$:

Input Offset Voltage				7.5	mV
Input Offset Current				300	nA
Input Bias Current				800	nA
Large-Signal Voltage Gain	$R_L \geq 2\text{ k}\Omega$, $V_{out} = \pm 10\text{ V}$	15,000			
Output Voltage Swing	$R_L \geq 2\text{ k}\Omega$	± 10	± 13		V

TYPICAL PERFORMANCE CURVES
393 GRADE

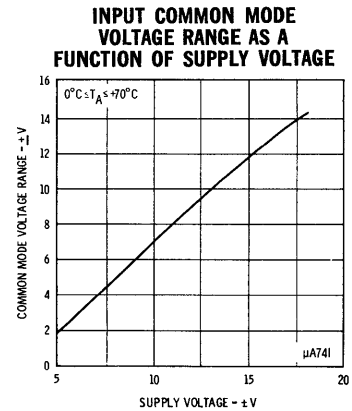
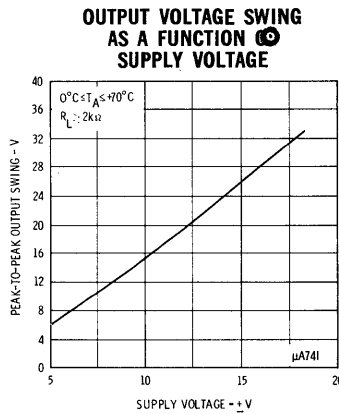
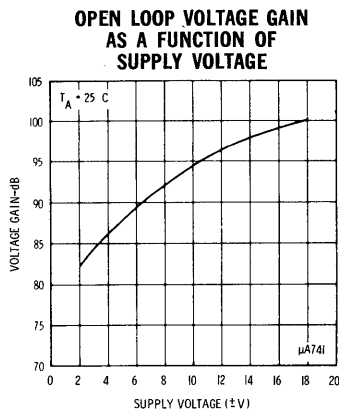

NOTES

- Rating applies to ambient temperatures up to 70°C . Above 70°C ambient derate linearly at $6.3\text{ mW}/^\circ\text{C}$ for the Metal Can, $8.3\text{ mW}/^\circ\text{C}$ for the Ceramic DIP, $6.3\text{ mW}/^\circ\text{C}$ for the Silicone DIP, $5.6\text{ mW}/^\circ\text{C}$ for the Mini DIP and $7.1\text{ mW}/^\circ\text{C}$ for the Flatpak.
- For supply voltages less than $\pm 15\text{ V}$, the absolute maximum input voltage is equal to the supply voltage.
- Short circuit may be to ground or either supply. Rating applies to $+125^\circ\text{C}$ case temperature or 75°C ambient temperature.

TYPICAL PERFORMANCE CURVES (312 GRADE)

INPUT BIAS CURRENT AS A FUNCTION OF AMBIENT TEMPERATURE

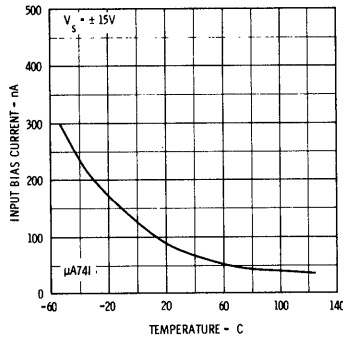

INPUT RESISTANCE AS A FUNCTION OF AMBIENT TEMPERATURE

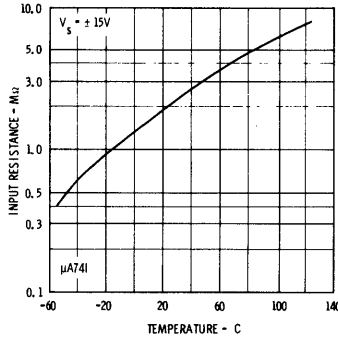

OUTPUT SHORT-CIRCUIT CURRENT AS A FUNCTION OF AMBIENT TEMPERATURE

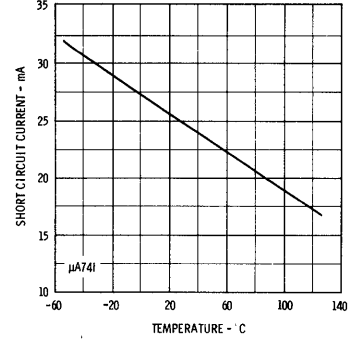

INPUT OFFSET CURRENT AS A FUNCTION OF AMBIENT TEMPERATURE

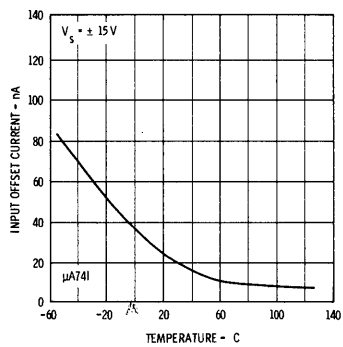

POWER CONSUMPTION AS A FUNCTION OF AMBIENT TEMPERATURE

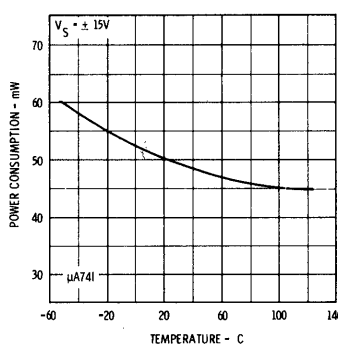

FREQUENCY CHARACTERISTICS AS A FUNCTION OF AMBIENT TEMPERATURE

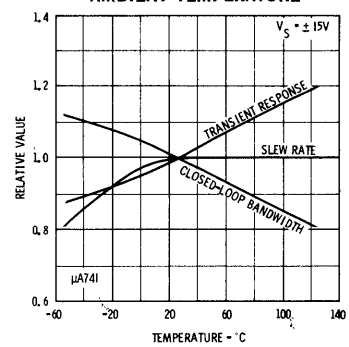

(393 GRADE)

INPUT BIAS CURRENT AS A FUNCTION OF AMBIENT TEMPERATURE

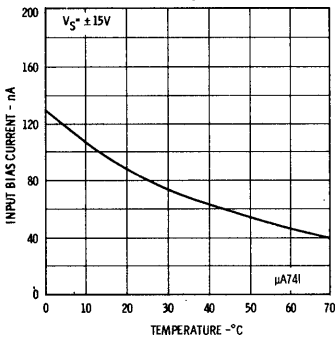

INPUT RESISTANCE AS A FUNCTION OF AMBIENT TEMPERATURE

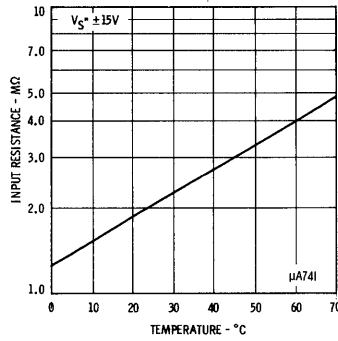

INPUT OFFSET CURRENT AS A FUNCTION OF AMBIENT TEMPERATURE

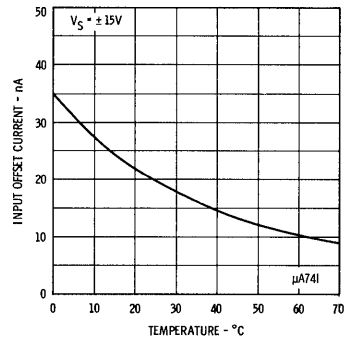

POWER CONSUMPTION AS A FUNCTION OF AMBIENT TEMPERATURE

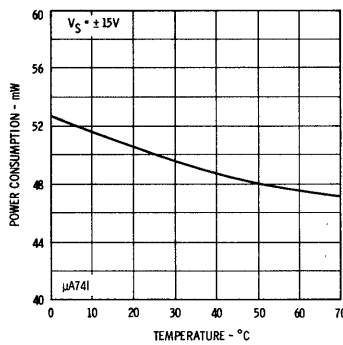

OUTPUT SHORT-CIRCUIT CURRENT AS A FUNCTION OF AMBIENT TEMPERATURE

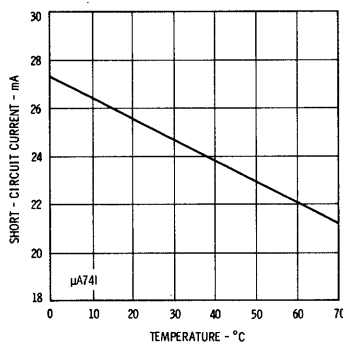

FREQUENCY CHARACTERISTICS AS A FUNCTION OF AMBIENT TEMPERATURE

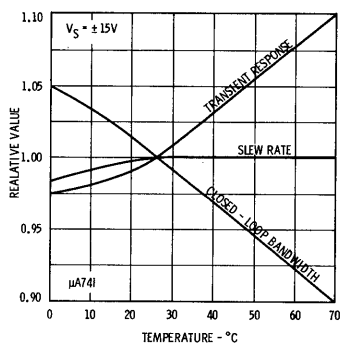

TYPICAL PERFORMANCE CURVES (312 AND 393 GRADES)

POWER CONSUMPTION AS A FUNCTION OF SUPPLY VOLTAGE

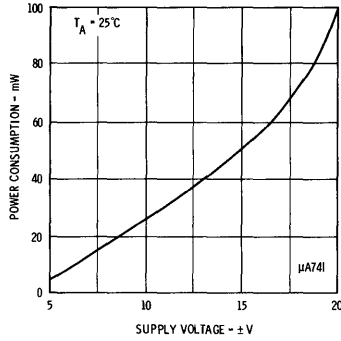

OPEN LOOP VOLTAGE GAIN AS A FUNCTION OF FREQUENCY

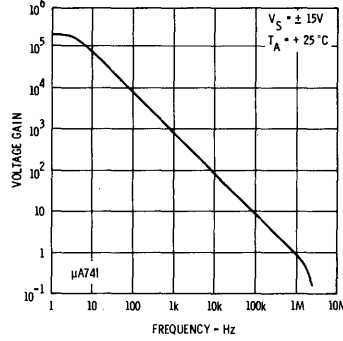

OPEN LOOP PHASE RESPONSE AS A FUNCTION OF FREQUENCY

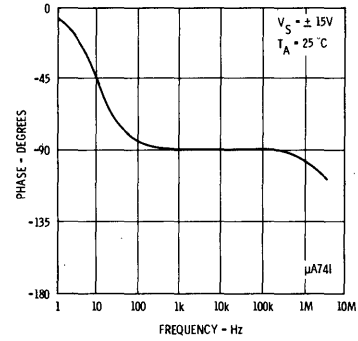

INPUT OFFSET CURRENT AS A FUNCTION OF SUPPLY VOLTAGE

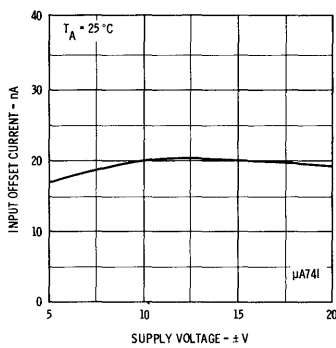

INPUT RESISTANCE AND INPUT CAPACITANCE AS A FUNCTION OF FREQUENCY

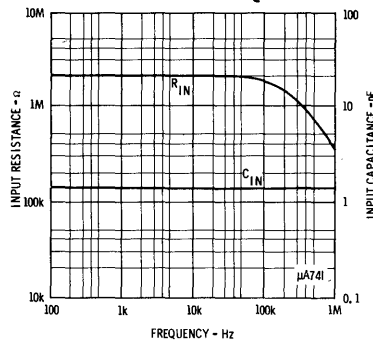

OUTPUT RESISTANCE AS A FUNCTION OF FREQUENCY

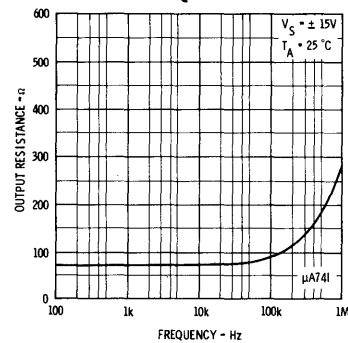

OUTPUT VOLTAGE SWING AS A FUNCTION OF LOAD RESISTANCE

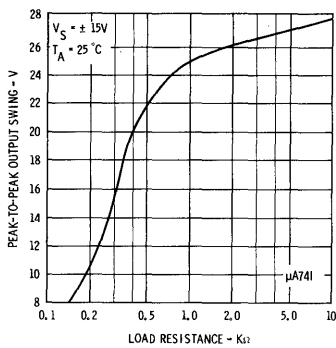

OUTPUT VOLTAGE SWING AS A FUNCTION OF FREQUENCY

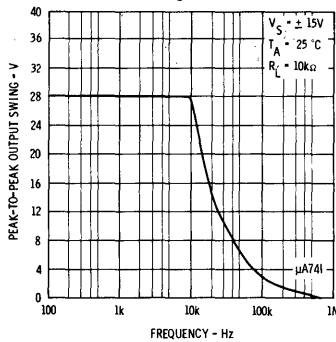

ABSOLUTE MAXIMUM POWER DISSIPATION AS A FUNCTION OF AMBIENT TEMPERATURE

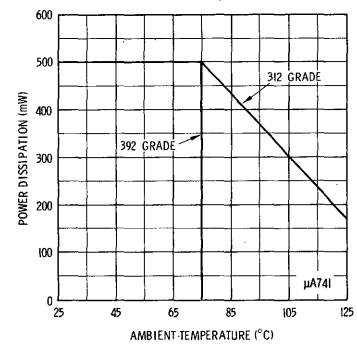

INPUT NOISE VOLTAGE AS A FUNCTION OF FREQUENCY

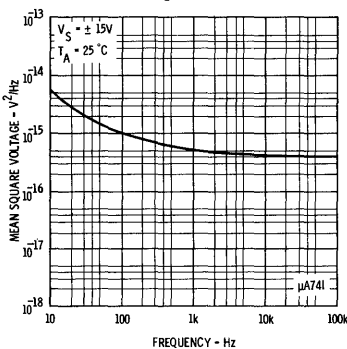

INPUT NOISE CURRENT AS A FUNCTION OF FREQUENCY

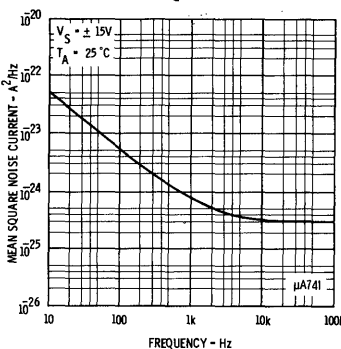

BROADBAND NOISE FOR VARIOUS BANDWIDTHS

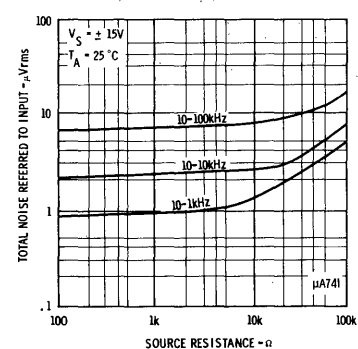

TRANSIENT RESPONSE

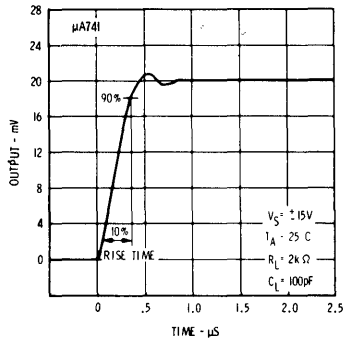

TRANSIENT RESPONSE TEST CIRCUIT

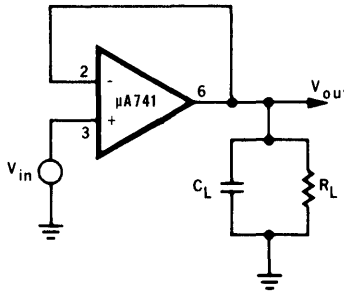

COMMON MODE REJECTION RATIO AS A FUNCTION OF FREQUENCY

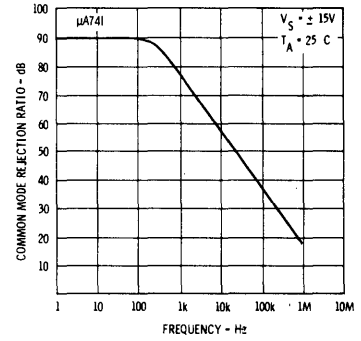

FREQUENCY CHARACTERISTICS AS A FUNCTION OF SUPPLY VOLTAGE

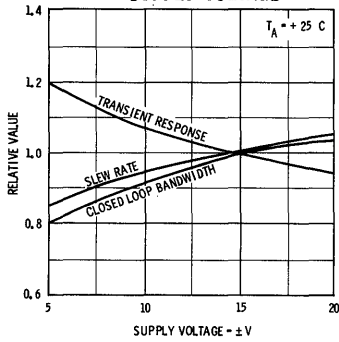

VOLTAGE OFFSET NULL CIRCUIT

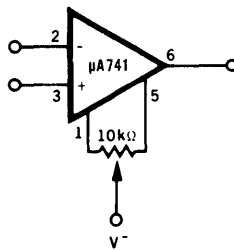

VOLTAGE FOLLOWER LARGE-SIGNAL PULSE RESPONSE

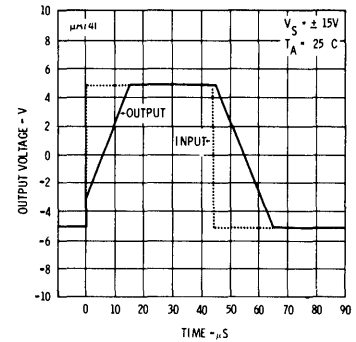

TYPICAL APPLICATIONS

UNITY-GAIN VOLTAGE FOLLOWER

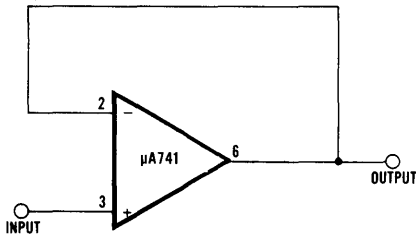

$R_{IN} = 400 M\Omega$
 $C_{IN} = 1 pF$
 $R_{out} \ll 1 \Omega$
 B.W. = 1 MHz

NON-INVERTING AMPLIFIER

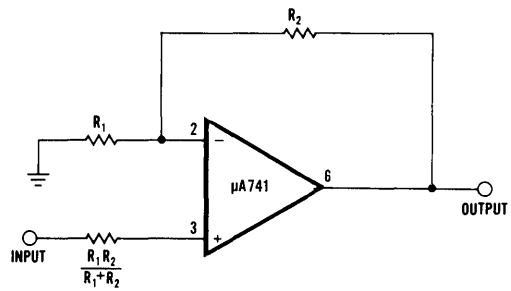

GAIN	R_1	R_2	B.W.	R_{IN}
10	1 k Ω	9 k Ω	100 kHz	400 M Ω
100	100 Ω	9.9 k Ω	10 kHz	280 M Ω
1000	100 Ω	99.9 k Ω	1 kHz	80 M Ω

INVERTING AMPLIFIER

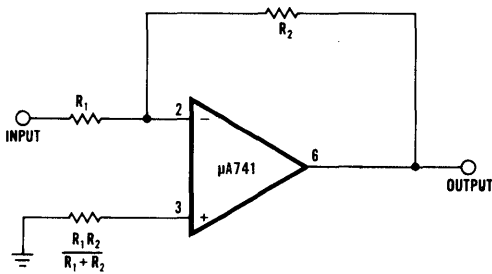

GAIN	R_1	R_2	B.W.	R_{IN}
1	10 k Ω	10 k Ω	1 MHz	10 k Ω
10	1 k Ω	10 k Ω	100 kHz	1 k Ω
100	1 k Ω	100 k Ω	10 kHz	1 k Ω
1000	100 Ω	100 k Ω	1 kHz	100 Ω

CLIPPING AMPLIFIER

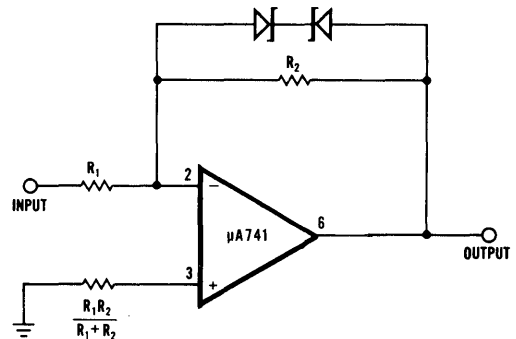

$$\frac{E_{out}}{E_{in}} = \frac{R_2}{R_1} \text{ if } |E_{out}| \leq V_Z + 0.7 V$$

where V_Z = Zener breakdown voltage

TYPICAL APPLICATIONS

SIMPLE INTEGRATOR

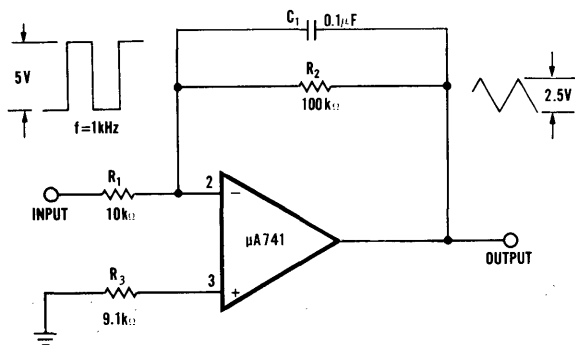

$$E_{out} = -\frac{1}{R_1 C_1} \int E_{in} dt$$

SIMPLE DIFFERENTIATOR

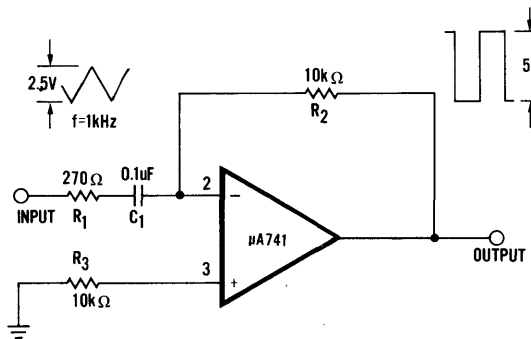

$$E_{out} = -R_2 C_1 \frac{dE_{in}}{dt}$$

LOW DRIFT LOW NOISE AMPLIFIER

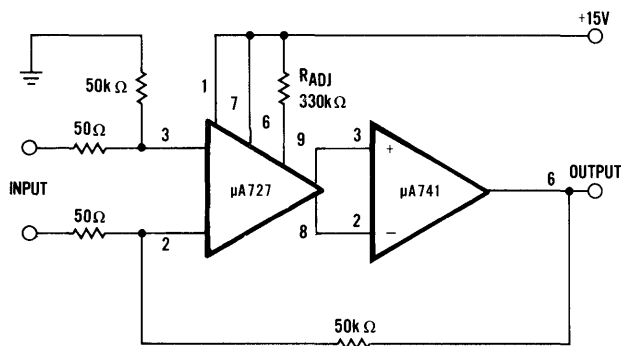

Voltage Gain = 10^3
 Input Offset Voltage Drift = $0.6 \mu V/^\circ C$
 Input Offset Current Drift = $2.0 pA/^\circ C$

HIGH SLEW RATE POWER AMPLIFIER

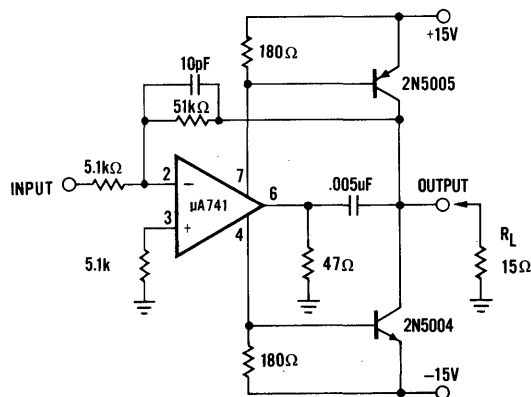

NOTCH FILTER USING THE $\mu A741$ AS A GYRATOR

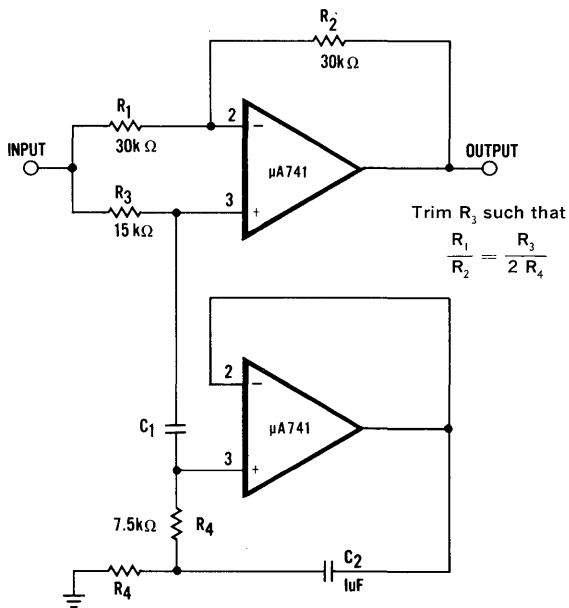

NOTCH FREQUENCY AS A FUNCTION OF C_1

